

Data sheet Nr.3

Piston Rod sealing

Mangione Consulting UG
 Schweriner Str 1
 42719 Solingen, Germany
 Phon: +49 157 8434 84 00
 Fax: +49 212 180 90 898
 mangione.consulting@gmail.com

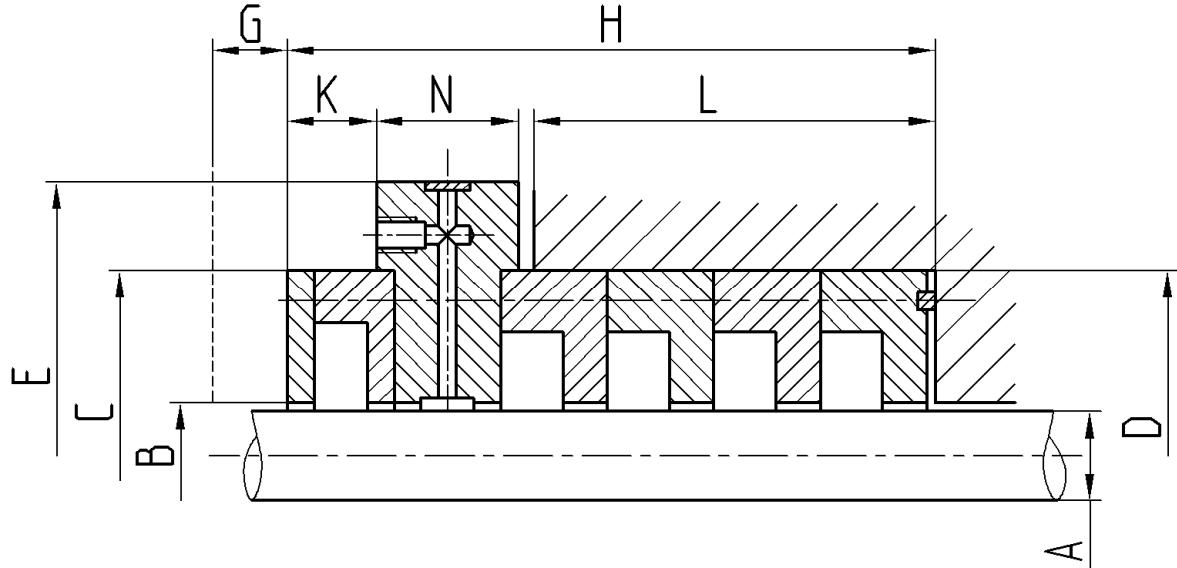

Measure, mm		Stage					
		1	2	3	4	5	6
Diameter, mm	A						
	B						
	C						
	D						
	E						
Fitting length,	L						
Complet length,	H						
Highness of channel head,	K						
Thickness of flange,	N						
Removal length,	G						
No. of sealing chambers							
No. of channel head							
No of holes in flange							
Diameter of holes							
Diameter of pitch circle							

Data sheet Nr.3

Piston Rod sealing

Mangione Consulting UG
Schweriner Str 1
42719 Solingen, Germany
Phon: +49 157 8434 84 00
Fax: +49 212 180 90 898
mangione.consulting@gmail.com

<i>Data</i>	<i>Stage</i>					
	1	2	3	4	5	6
Material of piston rod						
Hardness of piston rod material, HB						
Type of surface finishing						
Surface hardness of Piston rod, HV						
Throughtiness of surface of piston rod, Ra						
Lubricated, „Yes” or „No”						
Leakage gas pipeline, „Yes” or „No”						
Buffer gas, „Yes” or „No” Type of buffer gas						
Piston rod cooling „Yes” or „No” Type of cooling fluide						
Cylinder cooling, „Yes” or „No”						
Chamber cooling, „Yes” or „No”						

Data sheet Nr.3

Piston Rod sealing

Mangione Consulting UG
 Schweriner Str 1
 42719 Solingen, Germany
 Phon: +49 157 8434 84 00
 Fax: +49 212 180 90 898
 mangione.consulting@gmail.com

Throttle chamber

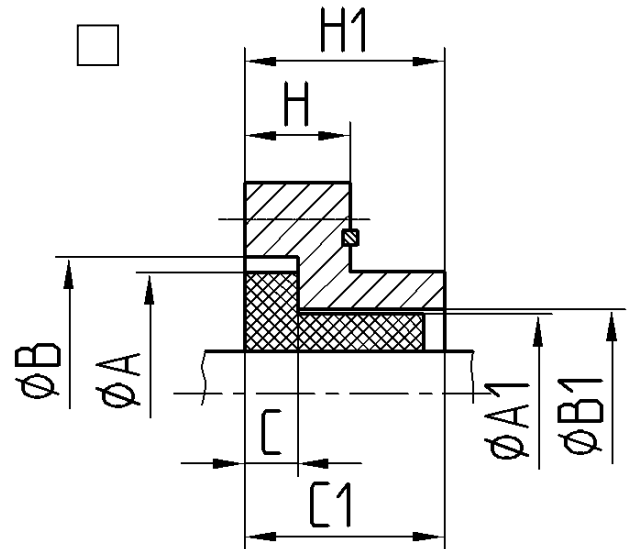
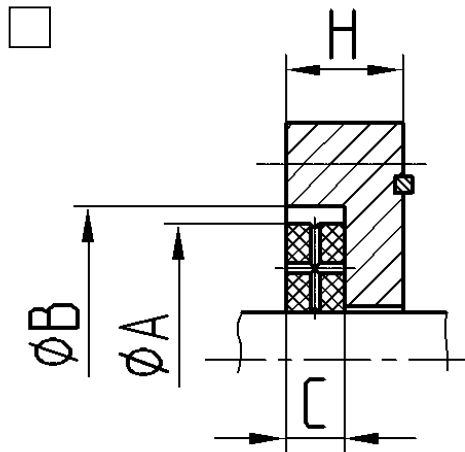

Stage No. 1 2 3 4 5 6

Stge No. 1 2 3 4 5
 6

Measure, mm		Stufe					
		1	2	3	4	5	6
Throttle chamber	A						
	B						
	C						
	H						
	A1						
	B1						
	C1						
	H1						

sign

Data sheet Nr.3

Piston Rod sealing

Mangione Consulting UG
 Schweriner Str 1
 42719 Solingen, Germany
 Phon: +49 157 8434 84 00
 Fax: +49 212 180 90 898
 mangione.consulting@gmail.com

Sealing chamber with support ring

Type No.1

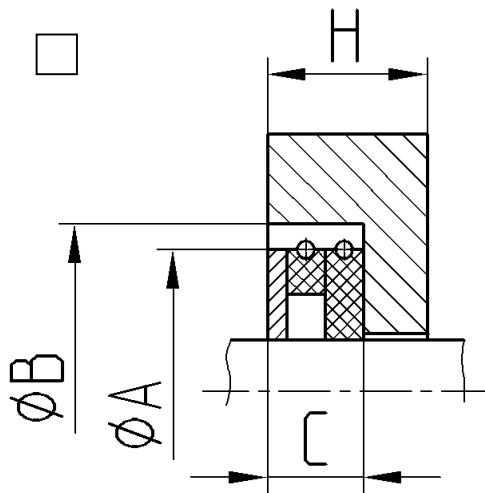

Stage No. 1 2 3 4 5
6
 Qty.

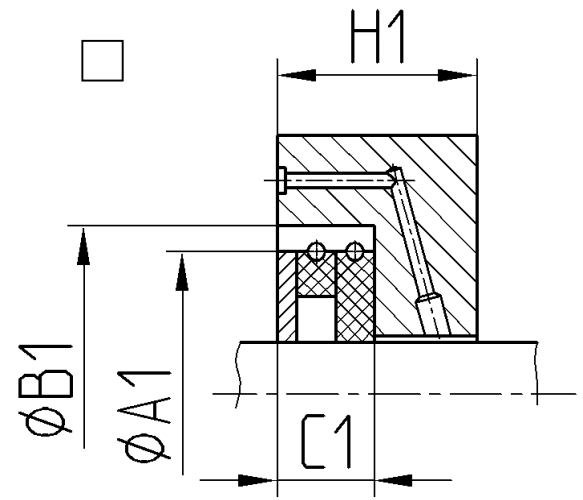

Stage No. 1 2 3 4 5
6
 Qty.

Type No.2

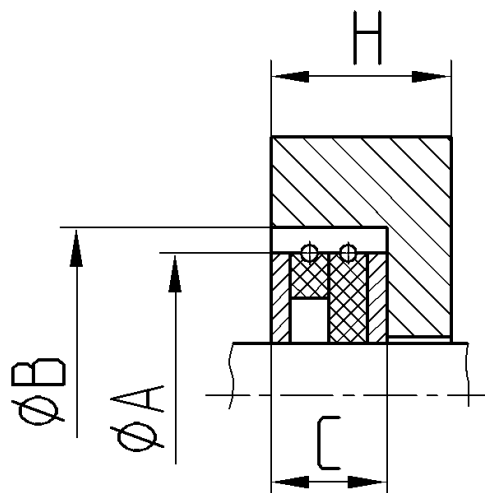

Stage No. 1 2 3 4 5
6
 Qty.

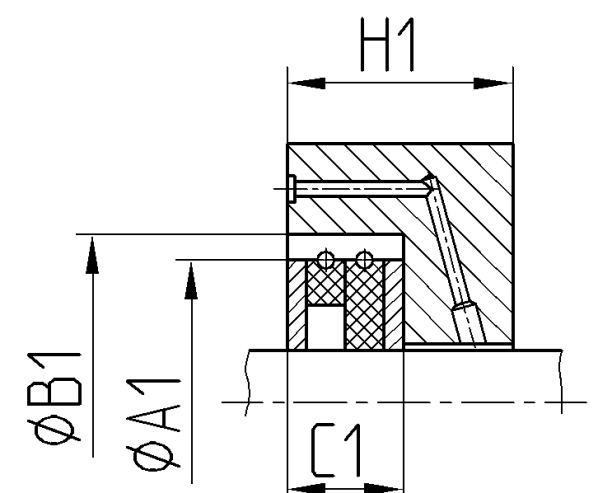

Stage No. 1 2 3 4 5
6
 Qty.

sign

Data sheet Nr.3

Piston Rod sealing

Mangione Consulting UG
 Schweriner Str 1
 42719 Solingen, Germany
 Phon: +49 157 8434 84 00
 Fax: +49 212 180 90 898
 mangione.consulting@gmail.com

Sealing chamber without support ring

Type No.1

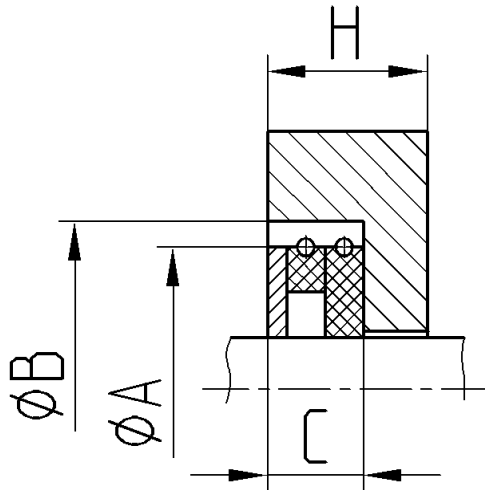

Stage No. 1 2 3 4 5

6
Qty.

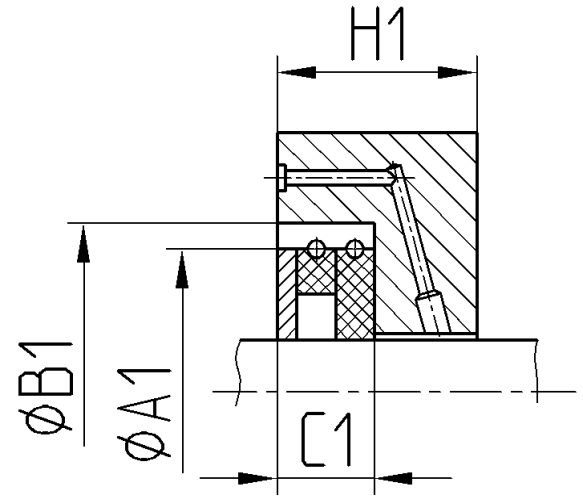

Stage No. 1 2 3 4 5

6
Qty.

Type No.2

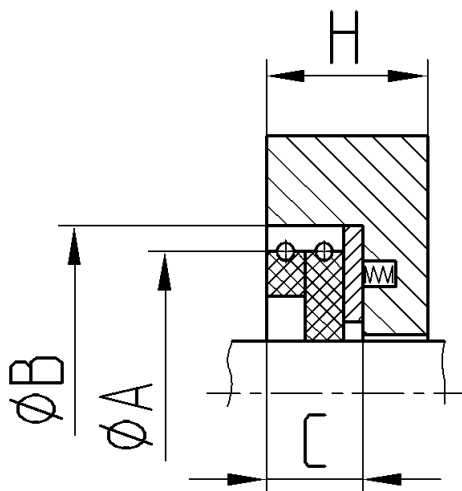

Stage No. 1 2 3 4 5

6
Qty.

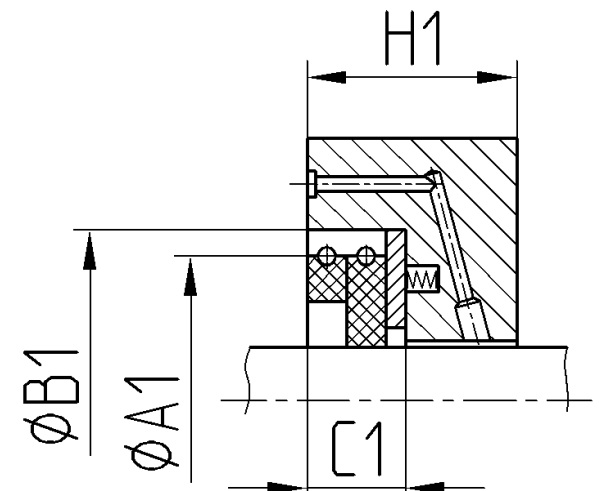

Stage No. 1 2 3 4 5

6
Qty.



sign.

Data sheet Nr.3

Piston Rod sealing

Mangione Consulting UG
 Schweriner Str 1
 42719 Solingen, Germany
 Phon: +49 157 8434 84 00
 Fax: +49 212 180 90 898
 mangione.consulting@gmail.com

Measure, mm		<i>Stage</i>						
		1	2	3	4	5	6	
Sealing chamber with support ring	<i>Type No.1</i>	A						
		B						
		C						
		H						
		A1						
		B1						
		C1						
		H1						
	<i>Type No.2</i>	A						
		B						
		C						
		H						
		A1						
		B1						
		C1						
		H1						

Sealing chamber without support ring	<i>Type No.1</i>	A						
		B						
		C						
		H						
		A1						
		B1						
		C1						
		H1						
	<i>Type No.2</i>	A						
		B						
		C						
		H						
		A1						
		B1						
		C1						
		H1						

Data sheet Nr.3

Piston Rod sealing

Mangione Consulting UG
 Schweriner Str 1
 42719 Solingen, Germany
 Phon: +49 157 8434 84 00
 Fax: +49 212 180 90 898
 mangione.consulting@gmail.com

Sealing of channel head

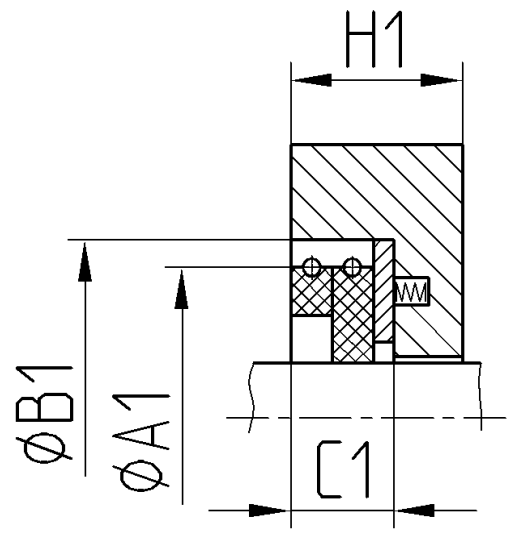
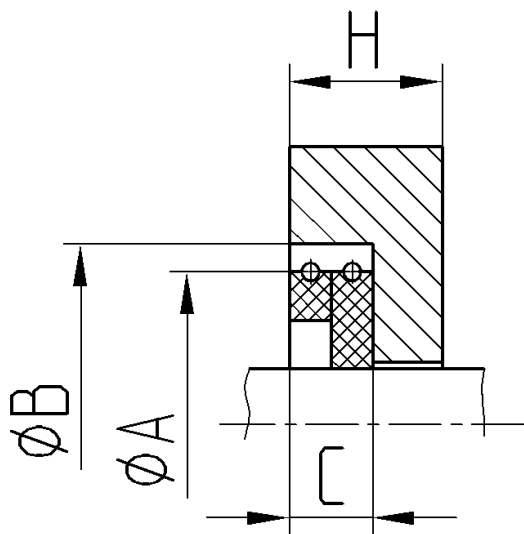

Stage No. 1 2 3 4 5

6

Qty.

Stage No. 1 2 3 4 5

6

Qty.

Measure, mm		Stage					
		1	2	3	4	5	6
Sealing of channel head	A						
	B						
	C						
	H						
	A1						
	B1						
	C1						
	H1						

Data sheet Nr.3

Piston Rod sealing

Mangione Consulting UG
 Schweriner Str 1
 42719 Solingen, Germany
 Phon: +49 157 8434 84 00
 Fax: +49 212 180 90 898
 mangione.consulting@gmail.com

Type of sealing

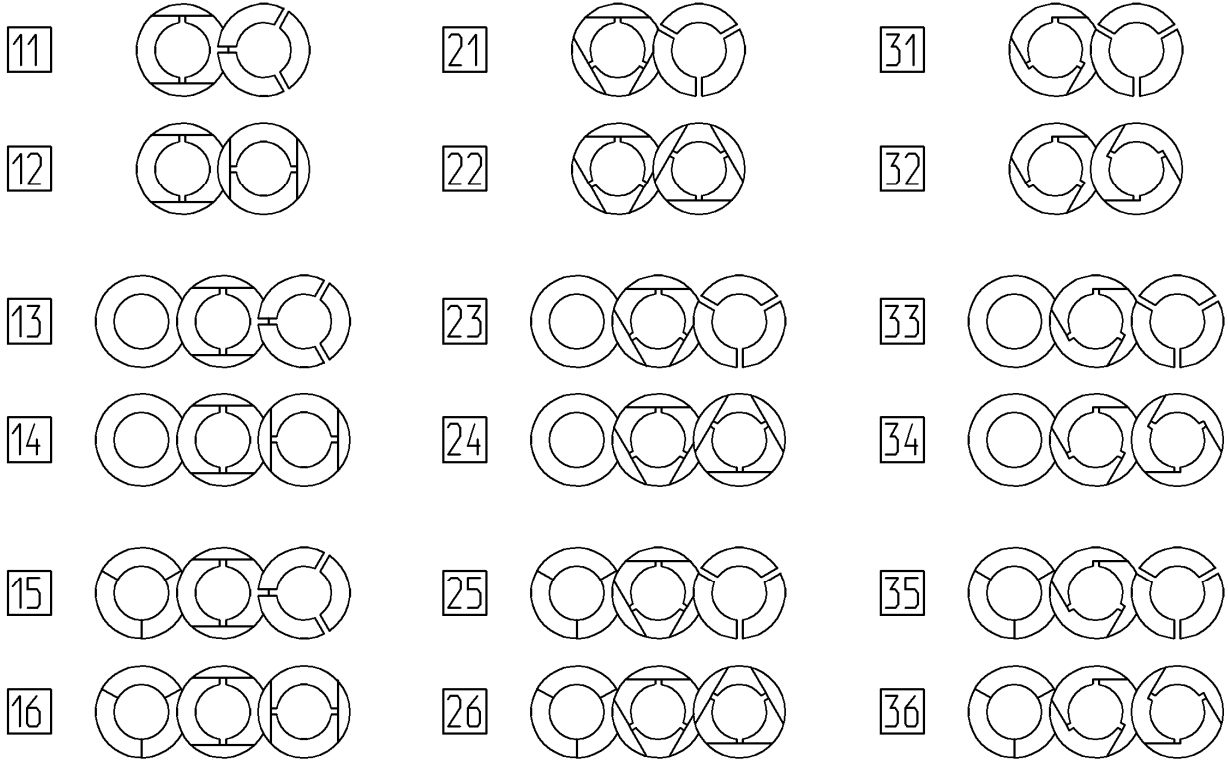

Type of sealing	Type No.	Stage					
		1	2	3	4	5	6
11							
12							
13							
14							
15							
16							
21							
22							
23							
24							
25							
26							
31							
32							
33							
34							
35							
36							